

OVERVIEW: “Around 13 people are killed and more than 1500 people are seriously injured each year whilst using ladders at work. Ladders are used in almost all employment sectors – sometimes for purposes other than those they were designed for. Their popularity often means that people underestimate the risks of using a ladder”. (See: HSC Proposals for work at height regulations). This Safety information bulletin provides some guidance on good practices to adopt when using ladders, especially at deck edges.

safety when using ladders

‘SADIE’ report 217 describes a fatal accident offshore in which a supervisor fell whilst descending a ladder. The ladder was designed to the appropriate British Standards and had a safety cage as a safety feature. However, he fell, according to the report, when ‘he lost 3-point contact with the ladder’, through the section between the ground and the first hoop of the cage onto a handrail ‘pivoting over it’ and then to the deck below. (See Step Change in Safety website: <http://www.stepchangeinsafety.net>)

There is always a risk of falling when using a ladder – even if it has safety features. Incorporating human factors into the design and careful usage, e.g. installing a safety cage or extended handrail and appropriately positioning ladders, can prevent serious consequences of falls.

Internal design standards

Information presented in this Safety information bulletin is for guidance – some organisations have internal design standards that require safety features in addition to those described here. In such cases, the internal standards should be adopted.

Safety recommendations

The following are generic safety measures that are intended to demystify work at height risk assessment. Dimensions are largely based on BS 5395-3:1985 and EEMUA *Factory stairways, ladders and handrails*. For offshore application in USA, refer to ABS *Guidance notes for the application of ergonomics to marine systems*.

1. Avoid positioning any ladder closer than 1 830 mm from a vertical drop (e.g. the edge of a deck or flat roof)
2. If this is unavoidable, install additional safety features – extended handrails, a safety cage, or both (see Figures 1 and 2). Fit a safety cage, or if not a fall-arrest system, whenever a user could fall 2 m or more or come into contact with dangerous equipment
3. If the ladder *does not* have a safety cage, extend the handrail in height to within 760 mm of the top of the ladder (see Figure 1)
4. If the ladder *does* have a safety cage, the handrail should be increased in height so that the distance between the bottom of the hoops and the top of the extended handrail is no more than 610 mm (see Figure 2)
5. Vertical gaps in the extended handrail should be no more than 470 mm (see Figure 2)
6. If the height of the handrail is increased, it should be strengthened
7. Handrails should be no less than 950 mm high and extend 1 220 mm either side of the ladder centre line
8. Install toe-boards at the drop edge at least 150 mm high.

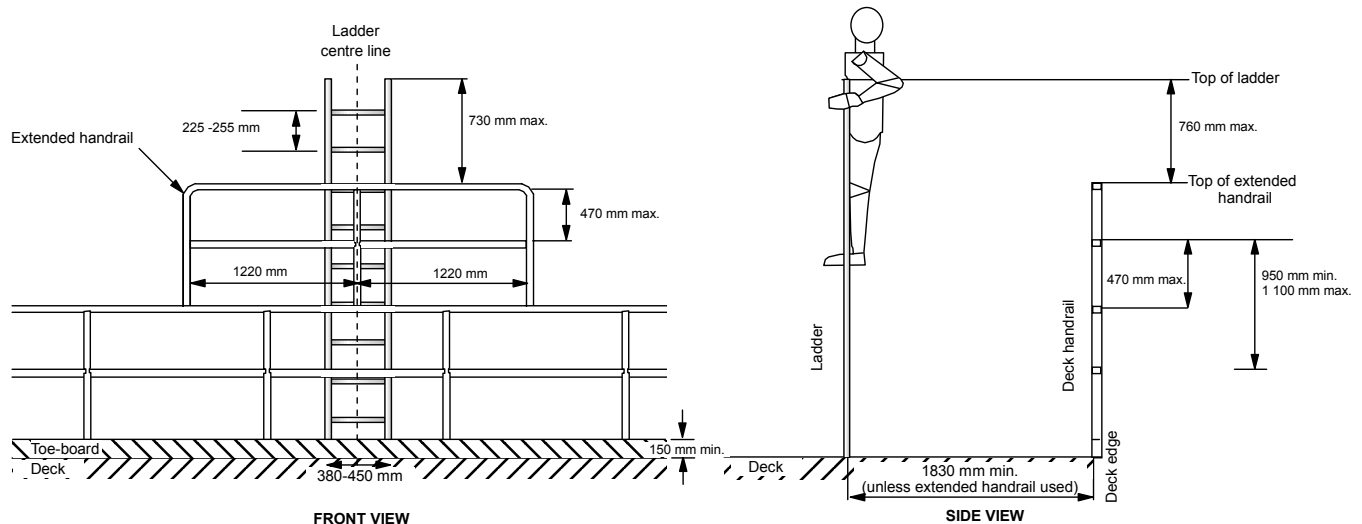

Figure 1 – Ladder and extended handrail to lower deck (without safety cage)

Notes:

1. Not to scale
2. Upper deck, its handrail and self-closing gate not shown.
3. Widened stringers to ladder at upper deck not shown.

Safety when using ladders (continued)

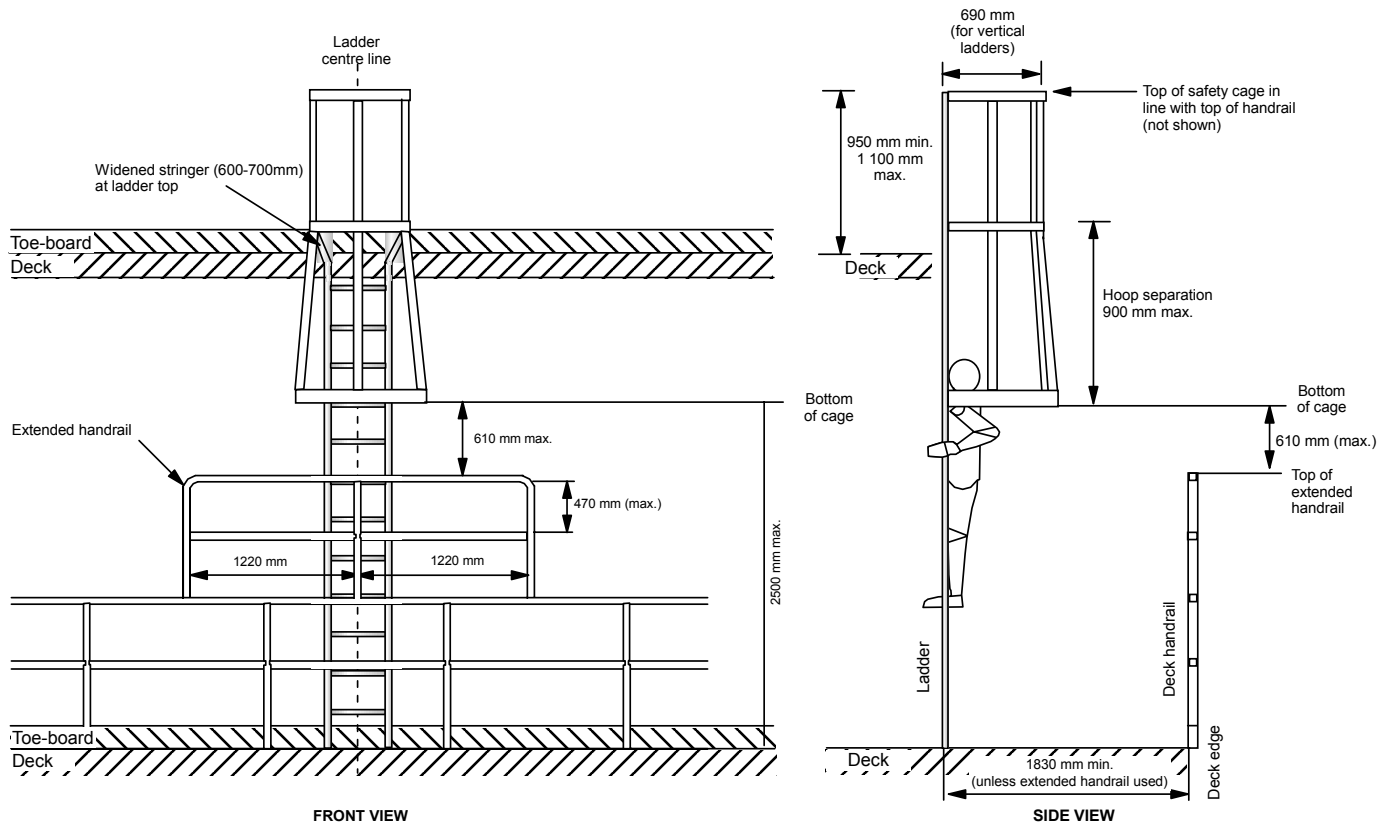

Figure 2 – Ladder and extended handrail to lower deck (with safety cage)

Notes:

1. Not to scale
2. Handrail and self-closing gate to upper deck not shown.

References and further information

HSC *Proposals for work at height regulations*, CD 192, HSE Books. See HSE website: <http://www.hse.gov.uk/consult/> and <http://www.hse.gov.uk/falls/>.

HSE *Height safe* (2003). See HSE website: <http://www.hse.gov.uk/pubns/index.htm>.

ABS *Guidance notes for the application of ergonomics to marine systems*, American Bureau of Shipping Publication No. 86 (2003). See ABS website: <http://www.eagle.org/>.

BS 5395-3:1985 *Stairs, ladders and walkways. Code of practice for the design of industrial type stairs, permanent ladders and walkways*, BSI, London (2000).

EEMUA *Factory stairways, ladders and handrails*, EEMUA Publication No. 105 (2002), ISBN 0 85931 041 8.